

### SAMPLE PROBLEM 2/1

The forces  $\mathbf{F}_1$ ,  $\mathbf{F}_2$ , and  $\mathbf{F}_3$ , all of which act on point  $A$  of the bracket, are specified in three different ways. Determine the  $x$  and  $y$  scalar components of each of the three forces.

**Solution.** The scalar components of  $\mathbf{F}_1$ , from Fig. *a*, are

$$F_{1x} = 600 \cos 35^\circ = 491 \text{ N} \quad \text{Ans.}$$

$$F_{1y} = 600 \sin 35^\circ = 344 \text{ N} \quad \text{Ans.}$$

The scalar components of  $\mathbf{F}_2$ , from Fig. *b*, are

$$F_{2x} = -500\left(\frac{4}{5}\right) = -400 \text{ N} \quad \text{Ans.}$$

$$F_{2y} = 500\left(\frac{3}{5}\right) = 300 \text{ N} \quad \text{Ans.}$$

Note that the angle which orients  $\mathbf{F}_2$  to the  $x$ -axis is never calculated. The cosine and sine of the angle are available by inspection of the 3-4-5 triangle. Also note that the  $x$  scalar component of  $\mathbf{F}_2$  is negative by inspection.

The scalar components of  $\mathbf{F}_3$  can be obtained by first computing the angle  $\alpha$  of Fig. *c*.

$$\alpha = \tan^{-1} \left[ \frac{0.2}{0.4} \right] = 26.6^\circ$$

$$\textcircled{1} \text{ Then, } F_{3x} = F_3 \sin \alpha = 800 \sin 26.6^\circ = 358 \text{ N} \quad \text{Ans.}$$

$$F_{3y} = -F_3 \cos \alpha = -800 \cos 26.6^\circ = -716 \text{ N} \quad \text{Ans.}$$

Alternatively, the scalar components of  $\mathbf{F}_3$  can be obtained by writing  $\mathbf{F}_3$  as a magnitude times a unit vector  $\mathbf{n}_{AB}$  in the direction of the line segment  $AB$ . Thus,

$$\begin{aligned} \textcircled{2} \quad \mathbf{F}_3 &= F_3 \mathbf{n}_{AB} = F_3 \frac{\overrightarrow{AB}}{AB} = 800 \left[ \frac{0.2\mathbf{i} - 0.4\mathbf{j}}{\sqrt{(0.2)^2 + (-0.4)^2}} \right] \\ &= 800 [0.447\mathbf{i} - 0.894\mathbf{j}] \\ &= 358\mathbf{i} - 716\mathbf{j} \text{ N} \end{aligned}$$

The required scalar components are then

$$F_{3x} = 358 \text{ N} \quad \text{Ans.}$$

$$F_{3y} = -716 \text{ N} \quad \text{Ans.}$$

which agree with our previous results.

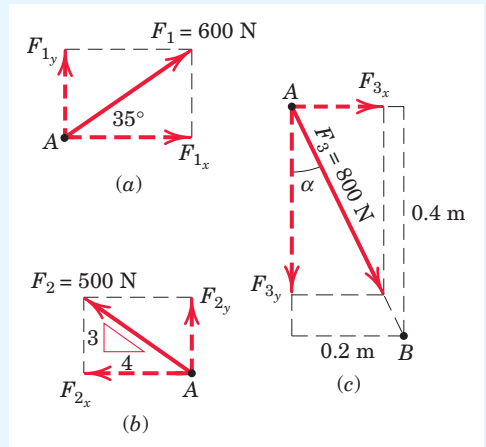
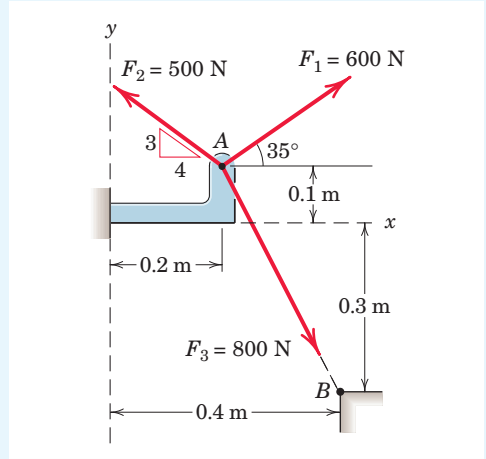

### Helpful Hints

- You should carefully examine the geometry of each component determination problem and not rely on the blind use of such formulas as  $F_x = F \cos \theta$  and  $F_y = F \sin \theta$ .
- A unit vector can be formed by dividing any vector, such as the geometric position vector  $\overrightarrow{AB}$ , by its length or magnitude. Here we use the overarrow to denote the vector which runs from  $A$  to  $B$  and the overbar to determine the distance between  $A$  and  $B$ .

## 30 Chapter 2 Force Systems

## SAMPLE PROBLEM 2/2

Combine the two forces  $\mathbf{P}$  and  $\mathbf{T}$ , which act on the fixed structure at  $B$ , into a single equivalent force  $\mathbf{R}$ .

- Graphical solution.** The parallelogram for the vector addition of forces  $\mathbf{T}$  and  $\mathbf{P}$  is constructed as shown in Fig. *a*. The scale used here is 1 in. = 800 lb; a scale of 1 in. = 200 lb would be more suitable for regular-size paper and would give greater accuracy. Note that the angle  $\alpha$  must be determined prior to construction of the parallelogram. From the given figure

$$\tan \alpha = \frac{\overline{BD}}{\overline{AD}} = \frac{6 \sin 60^\circ}{3 + 6 \cos 60^\circ} = 0.866 \quad \alpha = 40.9^\circ$$

Measurement of the length  $R$  and direction  $\theta$  of the resultant force  $\mathbf{R}$  yields the approximate results

$$R = 525 \text{ lb} \quad \theta = 49^\circ \quad \text{Ans.}$$

- Geometric solution.** The triangle for the vector addition of  $\mathbf{T}$  and  $\mathbf{P}$  is shown in Fig. *b*. The angle  $\alpha$  is calculated as above. The law of cosines gives

$$R^2 = (600)^2 + (800)^2 - 2(600)(800) \cos 40.9^\circ = 274,300$$

$$R = 524 \text{ lb} \quad \text{Ans.}$$

From the law of sines, we may determine the angle  $\theta$  which orients  $\mathbf{R}$ . Thus,

$$\frac{600}{\sin \theta} = \frac{524}{\sin 40.9^\circ} \quad \sin \theta = 0.750 \quad \theta = 48.6^\circ \quad \text{Ans.}$$

**Algebraic solution.** By using the  $x$ - $y$  coordinate system on the given figure, we may write

$$R_x = \Sigma F_x = 800 - 600 \cos 40.9^\circ = 346 \text{ lb}$$

$$R_y = \Sigma F_y = -600 \sin 40.9^\circ = -393 \text{ lb}$$

The magnitude and direction of the resultant force  $\mathbf{R}$  as shown in Fig. *c* are then

$$R = \sqrt{R_x^2 + R_y^2} = \sqrt{(346)^2 + (-393)^2} = 524 \text{ lb} \quad \text{Ans.}$$

$$\theta = \tan^{-1} \frac{|R_y|}{|R_x|} = \tan^{-1} \frac{393}{346} = 48.6^\circ \quad \text{Ans.}$$

The resultant  $\mathbf{R}$  may also be written in vector notation as

$$\mathbf{R} = R_x \mathbf{i} + R_y \mathbf{j} = 346 \mathbf{i} - 393 \mathbf{j} \text{ lb} \quad \text{Ans.}$$

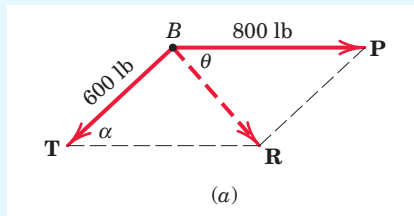
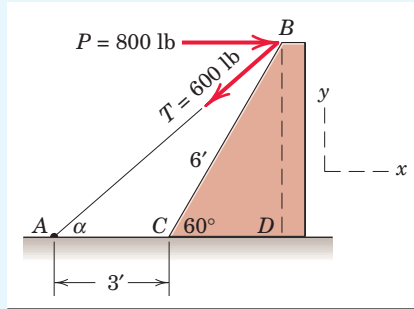

## Helpful Hints

- Note the repositioning of  $\mathbf{P}$  to permit parallelogram addition at  $B$ .

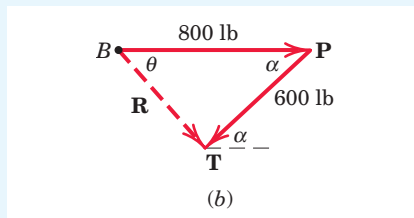

- Note the repositioning of  $\mathbf{F}$  so as to preserve the correct line of action of the resultant  $\mathbf{R}$ .

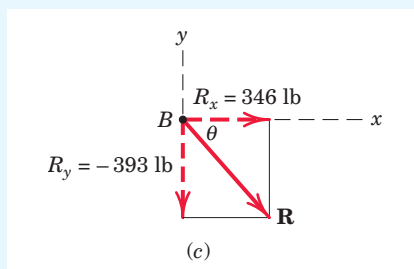

### SAMPLE PROBLEM 2/3

The 500-N force  $\mathbf{F}$  is applied to the vertical pole as shown. (1) Write  $\mathbf{F}$  in terms of the unit vectors  $\mathbf{i}$  and  $\mathbf{j}$  and identify both its vector and scalar components. (2) Determine the scalar components of the force vector  $\mathbf{F}$  along the  $x'$ - and  $y'$ -axes. (3) Determine the scalar components of  $\mathbf{F}$  along the  $x$ - and  $y$ -axes.

**Solution. Part (1).** From Fig. *a* we may write  $\mathbf{F}$  as

$$\begin{aligned}\mathbf{F} &= (F \cos \theta)\mathbf{i} - (F \sin \theta)\mathbf{j} \\ &= (500 \cos 60^\circ)\mathbf{i} - (500 \sin 60^\circ)\mathbf{j} \\ &= (250\mathbf{i} - 433\mathbf{j}) \text{ N} \quad \text{Ans.}\end{aligned}$$

The scalar components are  $F_x = 250$  N and  $F_y = -433$  N. The vector components are  $\mathbf{F}_x = 250\mathbf{i}$  N and  $\mathbf{F}_y = -433\mathbf{j}$  N.

**Part (2).** From Fig. *b* we may write  $\mathbf{F}$  as  $\mathbf{F} = 500\mathbf{i}'$  N, so that the required scalar components are

$$F_{x'} = 500 \text{ N} \quad F_{y'} = 0 \quad \text{Ans.}$$

**Part (3).** The components of  $\mathbf{F}$  in the  $x$ - and  $y'$ -directions are nonrectangular and are obtained by completing the parallelogram as shown in Fig. *c*. The magnitudes of the components may be calculated by the law of sines. Thus,

$$\begin{aligned}\frac{|F_x|}{\sin 90^\circ} &= \frac{500}{\sin 30^\circ} & |F_x| &= 1000 \text{ N} \\ \frac{|F_{y'}|}{\sin 60^\circ} &= \frac{500}{\sin 30^\circ} & |F_{y'}| &= 866 \text{ N}\end{aligned}$$

The required scalar components are then

$$F_x = 1000 \text{ N} \quad F_{y'} = -866 \text{ N} \quad \text{Ans.}$$

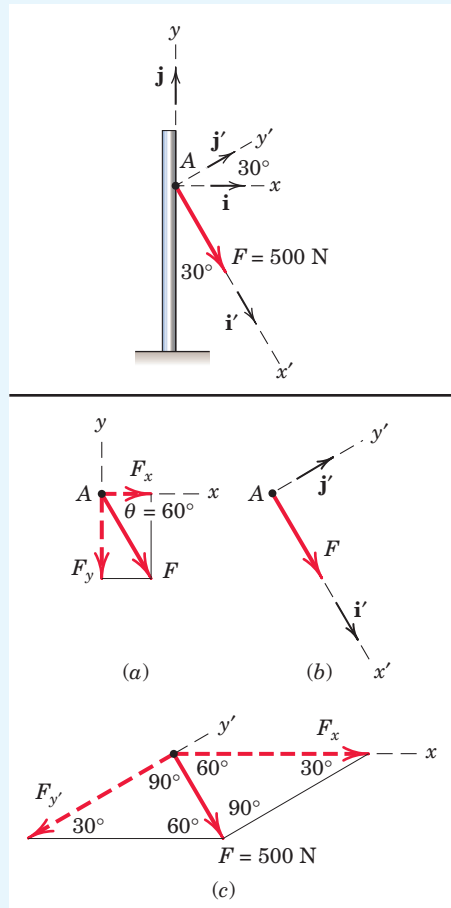

#### Helpful Hint

- 1 Obtain  $F_x$  and  $F_y$  graphically and compare your results with the calculated values.

### SAMPLE PROBLEM 2/4

Forces  $\mathbf{F}_1$  and  $\mathbf{F}_2$  act on the bracket as shown. Determine the projection  $F_b$  of their resultant  $\mathbf{R}$  onto the  $b$ -axis.

**Solution.** The parallelogram addition of  $\mathbf{F}_1$  and  $\mathbf{F}_2$  is shown in the figure. Using the law of cosines gives us

$$R^2 = (80)^2 + (100)^2 - 2(80)(100) \cos 130^\circ \quad R = 163.4 \text{ N}$$

The figure also shows the orthogonal projection  $F_b$  of  $\mathbf{R}$  onto the  $b$ -axis. Its length is

$$F_b = 80 + 100 \cos 50^\circ = 144.3 \text{ N} \quad \text{Ans.}$$

Note that the components of a vector are in general not equal to the projections of the vector onto the same axes. If the  $a$ -axis had been perpendicular to the  $b$ -axis, then the projections and components of  $\mathbf{R}$  would have been equal.

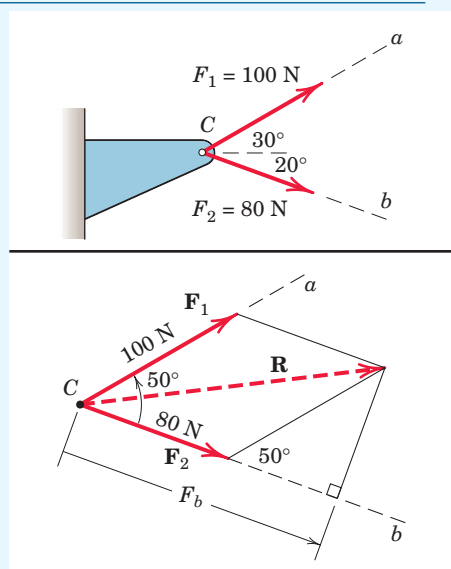

### SAMPLE PROBLEM 2/5

Calculate the magnitude of the moment about the base point  $O$  of the 600-N force in five different ways.

**Solution.** (I) The moment arm to the 600-N force is

$$d = 4 \cos 40^\circ + 2 \sin 40^\circ = 4.35 \text{ m}$$

- 1 By  $M = Fd$  the moment is clockwise and has the magnitude

$$M_O = 600(4.35) = 2610 \text{ N}\cdot\text{m}$$

(II) Replace the force by its rectangular components at  $A$ ,

$$F_1 = 600 \cos 40^\circ = 460 \text{ N}, \quad F_2 = 600 \sin 40^\circ = 386 \text{ N}$$

By Varignon's theorem, the moment becomes

- 2  $M_O = 460(4) + 386(2) = 2610 \text{ N}\cdot\text{m}$

(III) By the principle of transmissibility, move the 600-N force along its line of action to point  $B$ , which eliminates the moment of the component  $F_2$ . The moment arm of  $F_1$  becomes

$$d_1 = 4 + 2 \tan 40^\circ = 5.68 \text{ m}$$

and the moment is

$$M_O = 460(5.68) = 2610 \text{ N}\cdot\text{m}$$

- 3 (IV) Moving the force to point  $C$  eliminates the moment of the component  $F_1$ . The moment arm of  $F_2$  becomes

$$d_2 = 2 + 4 \cot 40^\circ = 6.77 \text{ m}$$

and the moment is

$$M_O = 386(6.77) = 2610 \text{ N}\cdot\text{m}$$

(V) By the vector expression for a moment, and by using the coordinate system indicated on the figure together with the procedures for evaluating cross products, we have

- 4 
$$\begin{aligned} \mathbf{M}_O &= \mathbf{r} \times \mathbf{F} = (2\mathbf{i} + 4\mathbf{j}) \times 600(\mathbf{i} \cos 40^\circ - \mathbf{j} \sin 40^\circ) \\ &= -2610\mathbf{k} \text{ N}\cdot\text{m} \end{aligned}$$

The minus sign indicates that the vector is in the negative  $z$ -direction. The magnitude of the vector expression is

$$M_O = 2610 \text{ N}\cdot\text{m}$$

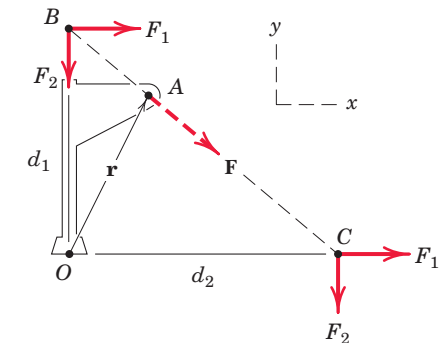
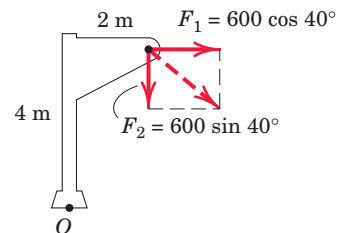
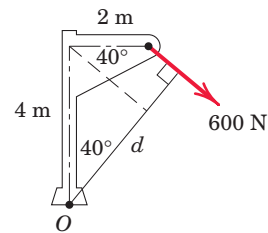
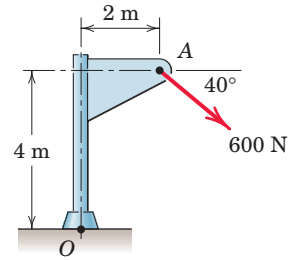

#### Helpful Hints

- 1 The required geometry here and in similar problems should not cause difficulty if the sketch is carefully drawn.
- 2 This procedure is frequently the shortest approach.
- 3 The fact that points  $B$  and  $C$  are not on the body proper should not cause concern, as the mathematical calculation of the moment of a force does not require that the force be on the body.
- 4 Alternative choices for the position vector  $\mathbf{r}$  are  $\mathbf{r} = d_1\mathbf{j} = 5.68\mathbf{j} \text{ m}$  and  $\mathbf{r} = d_2\mathbf{i} = 6.77\mathbf{i} \text{ m}$ .

Ans.

Ans.

Ans.

Ans.

Ans.

## 42 Chapter 2 Force Systems

## SAMPLE PROBLEM 2/6

The trap door  $OA$  is raised by the cable  $AB$ , which passes over the small frictionless guide pulleys at  $B$ . The tension everywhere in the cable is  $T$ , and this tension applied at  $A$  causes a moment  $M_O$  about the hinge at  $O$ . Plot the quantity  $M_O/T$  as a function of the door elevation angle  $\theta$  over the range  $0 \leq \theta \leq 90^\circ$  and note minimum and maximum values. What is the physical significance of this ratio?

**Solution.** We begin by constructing a figure which shows the tension force  $\mathbf{T}$  acting directly on the door, which is shown in an arbitrary angular position  $\theta$ . It should be clear that the direction of  $\mathbf{T}$  will vary as  $\theta$  varies. In order to deal with this variation, we write a unit vector  $\mathbf{n}_{AB}$  which “aims”  $\mathbf{T}$ :

$$\mathbf{n}_{AB} = \frac{\mathbf{r}_{AB}}{r_{AB}} = \frac{\mathbf{r}_{OB} - \mathbf{r}_{OA}}{r_{AB}}$$

Using the  $x$ - $y$  coordinates of our figure, we can write

$$\mathbf{r}_{OB} = 0.4\mathbf{j} \text{ m and } \mathbf{r}_{OA} = 0.5(\cos \theta \mathbf{i} + \sin \theta \mathbf{j}) \text{ m}$$

So

$$\begin{aligned} \mathbf{r}_{AB} &= \mathbf{r}_{OB} - \mathbf{r}_{OA} = 0.4\mathbf{j} - (0.5)(\cos \theta \mathbf{i} + \sin \theta \mathbf{j}) \\ &= -0.5 \cos \theta \mathbf{i} + (0.4 - 0.5 \sin \theta) \mathbf{j} \text{ m} \end{aligned}$$

and

$$\begin{aligned} r_{AB} &= \sqrt{(0.5 \cos \theta)^2 + (0.4 - 0.5 \sin \theta)^2} \\ &= \sqrt{0.41 - 0.4 \sin \theta} \text{ m} \end{aligned}$$

The desired unit vector is

$$\mathbf{n}_{AB} = \frac{\mathbf{r}_{AB}}{r_{AB}} = \frac{-0.5 \cos \theta \mathbf{i} + (0.4 - 0.5 \sin \theta) \mathbf{j}}{\sqrt{0.41 - 0.4 \sin \theta}}$$

Our tension vector can now be written as

$$\mathbf{T} = T\mathbf{n}_{AB} = T \left[ \frac{-0.5 \cos \theta \mathbf{i} + (0.4 - 0.5 \sin \theta) \mathbf{j}}{\sqrt{0.41 - 0.4 \sin \theta}} \right]$$

The moment of  $\mathbf{T}$  about point  $O$ , as a vector, is  $\mathbf{M}_O = \mathbf{r}_{OB} \times \mathbf{T}$ , where  $\mathbf{r}_{OB} = 0.4\mathbf{j}$  m, or

$$\begin{aligned} \mathbf{M}_O &= 0.4\mathbf{j} \times T \left[ \frac{-0.5 \cos \theta \mathbf{i} + (0.4 - 0.5 \sin \theta) \mathbf{j}}{\sqrt{0.41 - 0.4 \sin \theta}} \right] \\ &= \frac{0.2T \cos \theta}{\sqrt{0.41 - 0.4 \sin \theta}} \mathbf{k} \end{aligned}$$

The magnitude of  $\mathbf{M}_O$  is

$$M_O = \frac{0.2T \cos \theta}{\sqrt{0.41 - 0.4 \sin \theta}}$$

and the requested ratio is

$$\frac{M_O}{T} = \frac{0.2 \cos \theta}{\sqrt{0.41 - 0.4 \sin \theta}} \quad \text{Ans.}$$

which is plotted in the accompanying graph. The expression  $M_O/T$  is the moment arm  $d$  (in meters) which runs from  $O$  to the line of action of  $\mathbf{T}$ . It has a maximum value of 0.4 m at  $\theta = 53.1^\circ$  (at which point  $\mathbf{T}$  is horizontal) and a minimum value of 0 at  $\theta = 90^\circ$  (at which point  $\mathbf{T}$  is vertical). The expression is valid even if  $T$  varies.

This sample problem treats moments in two-dimensional force systems, and it also points out the advantages of carrying out a solution for an arbitrary position, so that behavior over a range of positions can be examined.

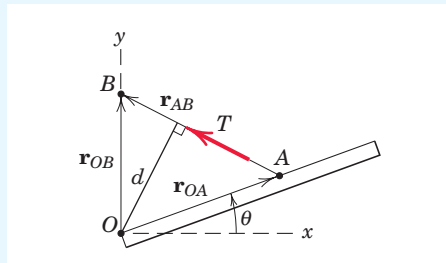
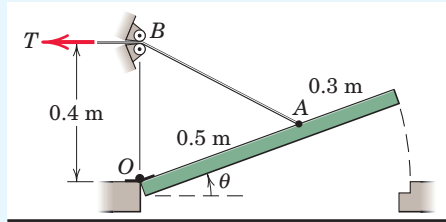

## Helpful Hints

1 Recall that any unit vector can be written as a vector divided by its magnitude. In this case the vector in the numerator is a position vector.

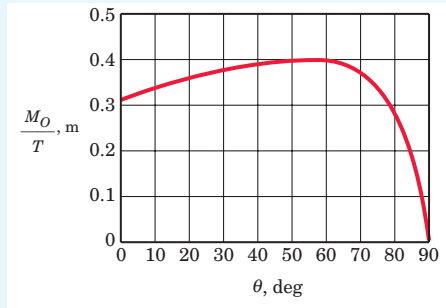

2 Recall that any vector may be written as a magnitude times an “aiming” unit vector.

3 In the expression  $\mathbf{M} = \mathbf{r} \times \mathbf{F}$ , the position vector  $\mathbf{r}$  runs from the moment center to any point on the line of action of  $\mathbf{F}$ . Here,  $\mathbf{r}_{OB}$  is more convenient than  $\mathbf{r}_{OA}$ .

## 52 Chapter 2 Force Systems

## SAMPLE PROBLEM 2/7

The rigid structural member is subjected to a couple consisting of the two 100-N forces. Replace this couple by an equivalent couple consisting of the two forces  $\mathbf{P}$  and  $-\mathbf{P}$ , each of which has a magnitude of 400 N. Determine the proper angle  $\theta$ .

**Solution.** The original couple is counterclockwise when the plane of the forces is viewed from above, and its magnitude is

$$[M = Fd] \quad M = 100(0.1) = 10 \text{ N}\cdot\text{m}$$

The forces  $\mathbf{P}$  and  $-\mathbf{P}$  produce a counterclockwise couple

$$M = 400(0.040) \cos \theta$$

- 1 Equating the two expressions gives

$$10 = (400)(0.040) \cos \theta$$

$$\theta = \cos^{-1} \frac{10}{16} = 51.3^\circ$$

Ans.

## Helpful Hint

- 1 Since the two equal couples are parallel free vectors, the only dimensions which are relevant are those which give the perpendicular distances between the forces of the couples.

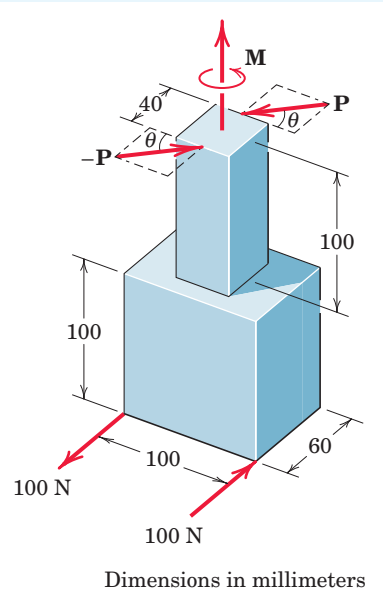

Dimensions in millimeters

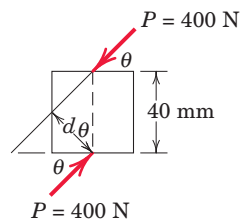

## SAMPLE PROBLEM 2/8

Replace the horizontal 80-lb force acting on the lever by an equivalent system consisting of a force at  $O$  and a couple.

**Solution.** We apply two equal and opposite 80-lb forces at  $O$  and identify the counterclockwise couple

$$[M = Fd] \quad M = 80(9 \sin 60^\circ) = 624 \text{ lb}\cdot\text{in.} \quad \text{Ans.}$$

- 1 Thus, the original force is equivalent to the 80-lb force at  $O$  and the 624-lb-in. couple as shown in the third of the three equivalent figures.

## Helpful Hint

- 1 The reverse of this problem is often encountered, namely, the replacement of a force and a couple by a single force. Proceeding in reverse is the same as replacing the couple by two forces, one of which is equal and opposite to the 80-lb force at  $O$ . The moment arm to the second force would be  $M/F = 624/80 = 7.79 \text{ in.}$ , which is  $9 \sin 60^\circ$ , thus determining the line of action of the single resultant force of 80 lb.

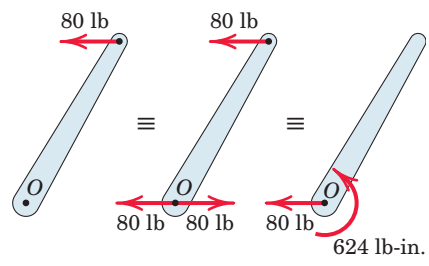
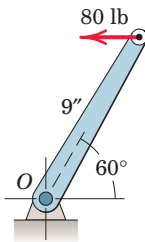

## SAMPLE PROBLEM 2/9

Determine the resultant of the four forces and one couple which act on the plate shown.

**Solution.** Point  $O$  is selected as a convenient reference point for the force–couple system which is to represent the given system.

$$[R_x = \Sigma F_x] \quad R_x = 40 + 80 \cos 30^\circ - 60 \cos 45^\circ = 66.9 \text{ N}$$

$$[R_y = \Sigma F_y] \quad R_y = 50 + 80 \sin 30^\circ + 60 \cos 45^\circ = 132.4 \text{ N}$$

$$[R = \sqrt{R_x^2 + R_y^2}] \quad R = \sqrt{(66.9)^2 + (132.4)^2} = 148.3 \text{ N} \quad \text{Ans.}$$

$$\left[ \theta = \tan^{-1} \frac{R_y}{R_x} \right] \quad \theta = \tan^{-1} \frac{132.4}{66.9} = 63.2^\circ \quad \text{Ans.}$$

$$\begin{aligned} \textcircled{1} [M_O = \Sigma(Fd)] \quad M_O &= 140 - 50(5) + 60 \cos 45^\circ(4) - 60 \sin 45^\circ(7) \\ &= -237 \text{ N}\cdot\text{m} \end{aligned}$$

The force–couple system consisting of  $\mathbf{R}$  and  $M_O$  is shown in Fig.  $a$ .

We now determine the final line of action of  $\mathbf{R}$  such that  $\mathbf{R}$  alone represents the original system.

$$[Rd = |M_O|] \quad 148.3d = 237 \quad d = 1.600 \text{ m} \quad \text{Ans.}$$

Hence, the resultant  $\mathbf{R}$  may be applied at any point on the line which makes a  $63.2^\circ$  angle with the  $x$ -axis and is tangent at point  $A$  to a circle of 1.600-m radius with center  $O$ , as shown in part  $b$  of the figure. We apply the equation  $Rd = M_O$  in an absolute-value sense (ignoring any sign of  $M_O$ ) and let the physics of the situation, as depicted in Fig.  $a$ , dictate the final placement of  $\mathbf{R}$ . Had  $M_O$  been counterclockwise, the correct line of action of  $\mathbf{R}$  would have been the tangent at point  $B$ .

The resultant  $\mathbf{R}$  may also be located by determining its intercept distance  $b$  to point  $C$  on the  $x$ -axis, Fig.  $c$ . With  $R_x$  and  $R_y$  acting through point  $C$ , only  $R_y$  exerts a moment about  $O$  so that

$$R_y b = |M_O| \quad \text{and} \quad b = \frac{237}{132.4} = 1.792 \text{ m}$$

Alternatively, the  $y$ -intercept could have been obtained by noting that the moment about  $O$  would be due to  $R_x$  only.

A more formal approach in determining the final line of action of  $\mathbf{R}$  is to use the vector expression

$$\mathbf{r} \times \mathbf{R} = \mathbf{M}_O$$

where  $\mathbf{r} = x\mathbf{i} + y\mathbf{j}$  is a position vector running from point  $O$  to any point on the line of action of  $\mathbf{R}$ . Substituting the vector expressions for  $\mathbf{r}$ ,  $\mathbf{R}$ , and  $\mathbf{M}_O$  and carrying out the cross product result in

$$(x\mathbf{i} + y\mathbf{j}) \times (66.9\mathbf{i} + 132.4\mathbf{j}) = -237\mathbf{k}$$

$$(132.4x - 66.9y)\mathbf{k} = -237\mathbf{k}$$

Thus, the desired line of action, Fig.  $c$ , is given by

$$132.4x - 66.9y = -237$$

$$\textcircled{2} \text{ By setting } y = 0, \text{ we obtain } x = -1.792 \text{ m, which agrees with our earlier calculation of the distance } b.$$

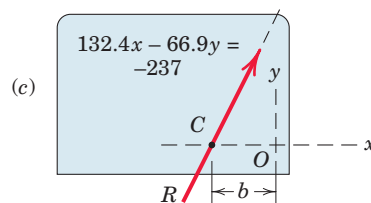
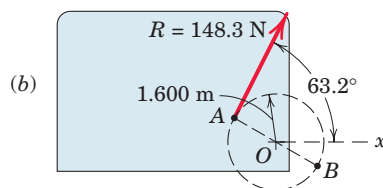
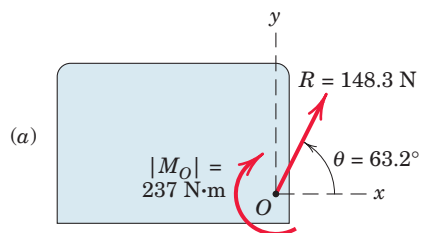
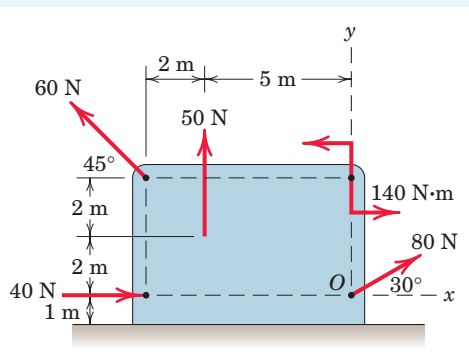

## Helpful Hints

- We note that the choice of point  $O$  as a moment center eliminates any moments due to the two forces which pass through  $O$ . Had the clockwise sign convention been adopted,  $M_O$  would have been  $+237 \text{ N}\cdot\text{m}$ , with the plus sign indicating a sense which agrees with the sign convention. Either sign convention, of course, leads to the conclusion of a clockwise moment  $M_O$ .
- Note that the vector approach yields sign information automatically, whereas the scalar approach is more physically oriented. You should master both methods.

### SAMPLE PROBLEM 2/10

A force  $\mathbf{F}$  with a magnitude of 100 N is applied at the origin  $O$  of the axes  $x$ - $y$ - $z$  as shown. The line of action of  $\mathbf{F}$  passes through a point  $A$  whose coordinates are 3 m, 4 m, and 5 m. Determine (a) the  $x$ ,  $y$ , and  $z$  scalar components of  $\mathbf{F}$ , (b) the projection  $F_{xy}$  of  $\mathbf{F}$  on the  $x$ - $y$  plane, and (c) the projection  $F_{OB}$  of  $\mathbf{F}$  along the line  $OB$ .

**Solution. Part (a).** We begin by writing the force vector  $\mathbf{F}$  as its magnitude  $F$  times a unit vector  $\mathbf{n}_{OA}$ .

$$\begin{aligned}\mathbf{F} &= F\mathbf{n}_{OA} = F \frac{\overrightarrow{OA}}{OA} = 100 \left[ \frac{3\mathbf{i} + 4\mathbf{j} + 5\mathbf{k}}{\sqrt{3^2 + 4^2 + 5^2}} \right] \\ &= 100[0.424\mathbf{i} + 0.566\mathbf{j} + 0.707\mathbf{k}] \\ &= 42.4\mathbf{i} + 56.6\mathbf{j} + 70.7\mathbf{k} \text{ N}\end{aligned}$$

The desired scalar components are thus

$$\textcircled{1} \quad F_x = 42.4 \text{ N} \quad F_y = 56.6 \text{ N} \quad F_z = 70.7 \text{ N} \quad \text{Ans.}$$

**Part (b).** The cosine of the angle  $\theta_{xy}$  between  $\mathbf{F}$  and the  $x$ - $y$  plane is

$$\cos \theta_{xy} = \frac{\sqrt{3^2 + 4^2}}{\sqrt{3^2 + 4^2 + 5^2}} = 0.707$$

so that  $F_{xy} = F \cos \theta_{xy} = 100(0.707) = 70.7 \text{ N}$

**Part (c).** The unit vector  $\mathbf{n}_{OB}$  along  $OB$  is

$$\mathbf{n}_{OB} = \frac{\overrightarrow{OB}}{OB} = \frac{6\mathbf{i} + 6\mathbf{j} + 2\mathbf{k}}{\sqrt{6^2 + 6^2 + 2^2}} = 0.688\mathbf{i} + 0.688\mathbf{j} + 0.229\mathbf{k}$$

The scalar projection of  $\mathbf{F}$  on  $OB$  is

$$\begin{aligned}\textcircled{2} \quad F_{OB} &= \mathbf{F} \cdot \mathbf{n}_{OB} = (42.4\mathbf{i} + 56.6\mathbf{j} + 70.7\mathbf{k}) \cdot (0.688\mathbf{i} + 0.688\mathbf{j} + 0.229\mathbf{k}) \\ &= (42.4)(0.688) + (56.6)(0.688) + (70.7)(0.229) \\ &= 84.4 \text{ N}\end{aligned}$$

If we wish to express the projection as a vector, we write

$$\begin{aligned}\mathbf{F}_{OB} &= \mathbf{F} \cdot \mathbf{n}_{OB} \mathbf{n}_{OB} \\ &= 84.4(0.688\mathbf{i} + 0.688\mathbf{j} + 0.229\mathbf{k}) \\ &= 58.1\mathbf{i} + 58.1\mathbf{j} + 19.35\mathbf{k} \text{ N}\end{aligned}$$

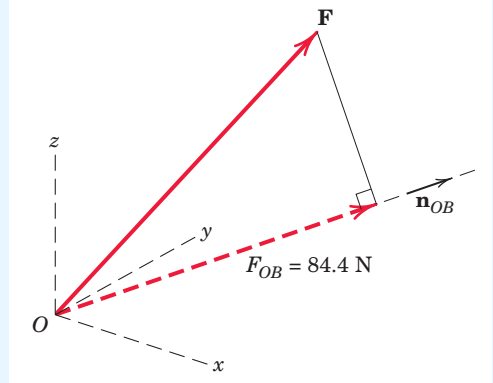
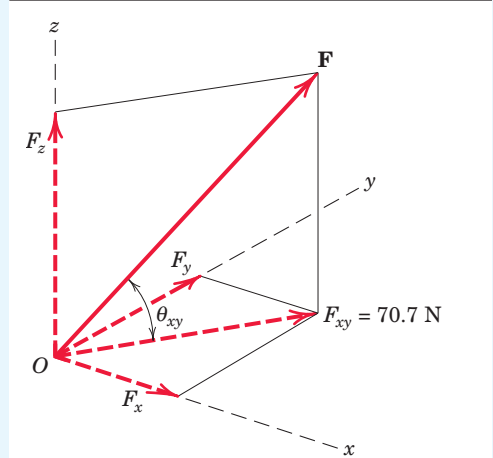
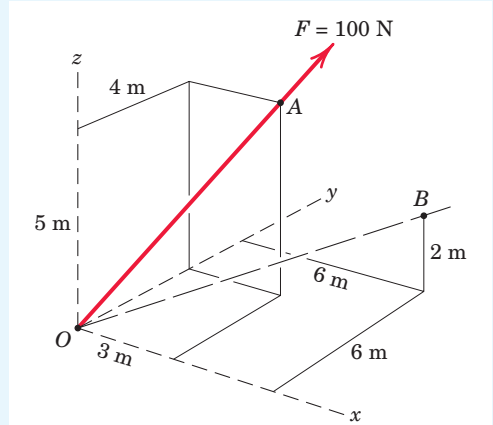

#### Helpful Hints

- 1 In this example all scalar components are positive. Be prepared for the case where a direction cosine, and hence the scalar component, are negative.
- 2 The dot product automatically finds the projection or scalar component of  $\mathbf{F}$  along line  $OB$  as shown.



## 78 Chapter 2 Force Systems

## SAMPLE PROBLEM 2/11

Determine the moment of force  $\mathbf{F}$  about point  $O$  (a) by inspection and (b) by the formal cross-product definition  $\mathbf{M}_O = \mathbf{r} \times \mathbf{F}$ .

**Solution.** (a) Because  $\mathbf{F}$  is parallel to the  $y$ -axis,  $\mathbf{F}$  has no moment about that axis. It should be clear that the moment arm from the  $x$ -axis to the line of action of  $\mathbf{F}$  is  $c$  and that the moment of  $\mathbf{F}$  about the  $x$ -axis is negative. Similarly, the moment arm from the  $z$ -axis to the line of action of  $\mathbf{F}$  is  $a$  and the moment of  $\mathbf{F}$  about the  $z$ -axis is positive. So we have

$$\mathbf{M}_O = -cF\mathbf{i} + aF\mathbf{k} = F(-c\mathbf{i} + a\mathbf{k}) \quad \text{Ans.}$$

(b) Formally,

$$\begin{aligned} \mathbf{M}_O = \mathbf{r} \times \mathbf{F} &= (a\mathbf{i} + c\mathbf{k}) \times F\mathbf{j} = aF\mathbf{k} - cF\mathbf{i} \\ &= F(-c\mathbf{i} + a\mathbf{k}) \quad \text{Ans.} \end{aligned}$$

## Helpful Hint

- 1 Again we stress that  $\mathbf{r}$  runs from the moment center to the line of action of  $\mathbf{F}$ . Another permissible, but less convenient, position vector is  $\mathbf{r} = a\mathbf{i} + b\mathbf{j} + c\mathbf{k}$ .

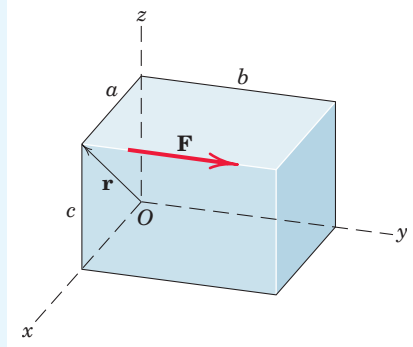
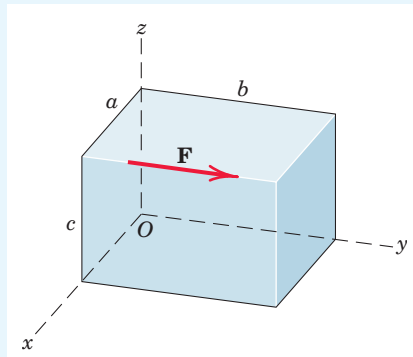

## SAMPLE PROBLEM 2/12

The turnbuckle is tightened until the tension in cable  $AB$  is 2.4 kN. Determine the moment about point  $O$  of the cable force acting on point  $A$  and the magnitude of this moment.

**Solution.** We begin by writing the described force as a vector.

$$\begin{aligned} \mathbf{T} = T\mathbf{n}_{AB} &= 2.4 \left[ \frac{0.8\mathbf{i} + 1.5\mathbf{j} - 2\mathbf{k}}{\sqrt{0.8^2 + 1.5^2 + 2^2}} \right] \\ &= 0.731\mathbf{i} + 1.371\mathbf{j} - 1.829\mathbf{k} \text{ kN} \end{aligned}$$

The moment of this force about point  $O$  is

$$\begin{aligned} \mathbf{M}_O = \mathbf{r}_{OA} \times \mathbf{T} &= (1.6\mathbf{i} + 2\mathbf{k}) \times (0.731\mathbf{i} + 1.371\mathbf{j} - 1.829\mathbf{k}) \\ &= -2.74\mathbf{i} + 4.39\mathbf{j} + 2.19\mathbf{k} \text{ kN}\cdot\text{m} \quad \text{Ans.} \end{aligned}$$

This vector has a magnitude

$$M_O = \sqrt{2.74^2 + 4.39^2 + 2.19^2} = 5.62 \text{ kN}\cdot\text{m} \quad \text{Ans.}$$

## Helpful Hint

- 1 The student should verify by inspection the signs of the moment components.

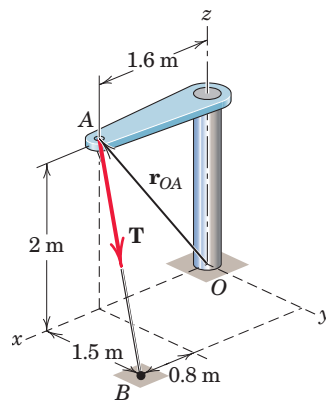
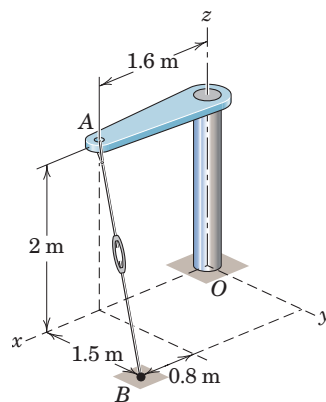

### SAMPLE PROBLEM 2/13

A tension  $\mathbf{T}$  of magnitude 10 kN is applied to the cable attached to the top  $A$  of the rigid mast and secured to the ground at  $B$ . Determine the moment  $M_z$  of  $\mathbf{T}$  about the  $z$ -axis passing through the base  $O$ .

**Solution (a).** The required moment may be obtained by finding the component along the  $z$ -axis of the moment  $\mathbf{M}_O$  of  $\mathbf{T}$  about point  $O$ . The vector  $\mathbf{M}_O$  is normal to the plane defined by  $\mathbf{T}$  and point  $O$ , as shown in the accompanying figure. In the use of Eq. 2/14 to find  $\mathbf{M}_O$ , the vector  $\mathbf{r}$  is any vector from point  $O$  to the line of action of  $\mathbf{T}$ . The simplest choice is the vector from  $O$  to  $A$ , which is written as  $\mathbf{r} = 15\mathbf{j}$  m. The vector expression for  $\mathbf{T}$  is

$$\begin{aligned}\mathbf{T} &= T\mathbf{n}_{AB} = 10 \left[ \frac{12\mathbf{i} - 15\mathbf{j} + 9\mathbf{k}}{\sqrt{(12)^2 + (-15)^2 + (9)^2}} \right] \\ &= 10(0.566\mathbf{i} - 0.707\mathbf{j} + 0.424\mathbf{k}) \text{ kN}\end{aligned}$$

From Eq. 2/14,

$$\begin{aligned}[\mathbf{M}_O = \mathbf{r} \times \mathbf{F}] \quad \mathbf{M}_O &= 15\mathbf{j} \times 10(0.566\mathbf{i} - 0.707\mathbf{j} + 0.424\mathbf{k}) \\ &= 150(-0.566\mathbf{k} + 0.424\mathbf{i}) \text{ kN}\cdot\text{m}\end{aligned}$$

The value  $M_z$  of the desired moment is the scalar component of  $\mathbf{M}_O$  in the  $z$ -direction or  $M_z = \mathbf{M}_O \cdot \mathbf{k}$ . Therefore,

$$M_z = 150(-0.566\mathbf{k} + 0.424\mathbf{i}) \cdot \mathbf{k} = -84.9 \text{ kN}\cdot\text{m} \quad \text{Ans.}$$

- 2 The minus sign indicates that the vector  $\mathbf{M}_z$  is in the negative  $z$ -direction. Expressed as a vector, the moment is  $\mathbf{M}_z = -84.9\mathbf{k}$  kN·m.

**Solution (b).** The force of magnitude  $T$  is resolved into components  $T_z$  and  $T_{xy}$  in the  $x$ - $y$  plane. Since  $T_z$  is parallel to the  $z$ -axis, it can exert no moment about this axis. The moment  $M_z$  is, then, due only to  $T_{xy}$  and is  $M_z = T_{xy}d$ , where  $d$  is the perpendicular distance from  $T_{xy}$  to  $O$ . The cosine of the angle between  $T$  and  $T_{xy}$  is  $\sqrt{15^2 + 12^2} / \sqrt{15^2 + 12^2 + 9^2} = 0.906$ , and therefore,

$$T_{xy} = 10(0.906) = 9.06 \text{ kN}$$

The moment arm  $d$  equals  $OA$  multiplied by the sine of the angle between  $T_{xy}$  and  $OA$ , or

$$d = 15 \frac{12}{\sqrt{12^2 + 15^2}} = 9.37 \text{ m}$$

Hence, the moment of  $\mathbf{T}$  about the  $z$ -axis has the magnitude

$$M_z = 9.06(9.37) = 84.9 \text{ kN}\cdot\text{m} \quad \text{Ans.}$$

and is clockwise when viewed in the  $x$ - $y$  plane.

**Solution (c).** The component  $T_{xy}$  is further resolved into its components  $T_x$  and  $T_y$ . It is clear that  $T_y$  exerts no moment about the  $z$ -axis since it passes through it, so that the required moment is due to  $T_x$  alone. The direction cosine of  $\mathbf{T}$  with respect to the  $x$ -axis is  $12/\sqrt{9^2 + 12^2 + 15^2} = 0.566$  so that  $T_x = 10(0.566) = 5.66$  kN. Thus,

$$M_z = 5.66(15) = 84.9 \text{ kN}\cdot\text{m} \quad \text{Ans.}$$

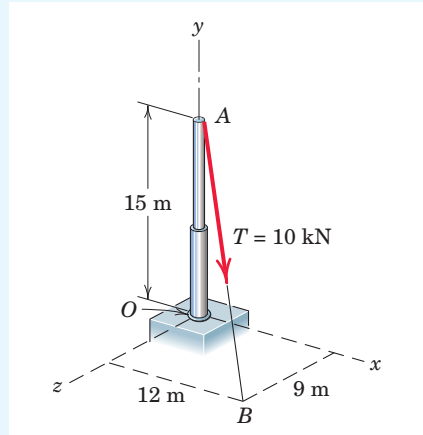

#### Helpful Hints

- 1 We could also use the vector from  $O$  to  $B$  for  $\mathbf{r}$  and obtain the same result, but using vector  $OA$  is simpler.
- 2 It is always helpful to accompany your vector operations with a sketch of the vectors so as to retain a clear picture of the geometry of the problem.
- 3 Sketch the  $x$ - $y$  view of the problem and show  $d$ .

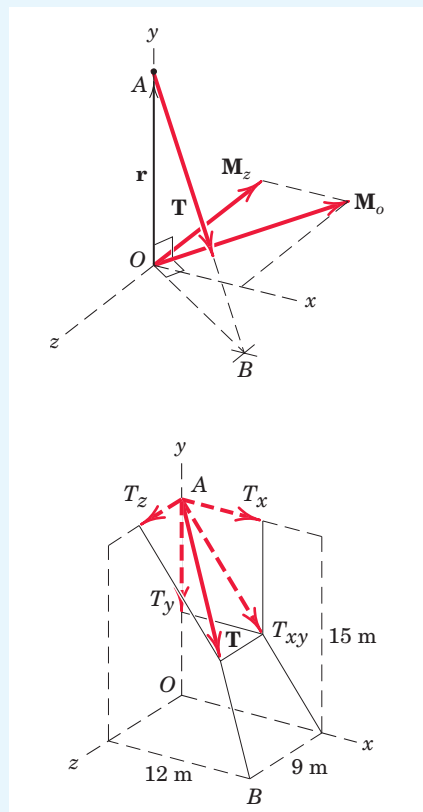

## 80 Chapter 2 Force Systems

## SAMPLE PROBLEM 2/14

Determine the magnitude and direction of the couple  $\mathbf{M}$  which will replace the two given couples and still produce the same external effect on the block. Specify the two forces  $\mathbf{F}$  and  $-\mathbf{F}$ , applied in the two faces of the block parallel to the  $y$ - $z$  plane, which may replace the four given forces. The 30-N forces act parallel to the  $y$ - $z$  plane.

**Solution.** The couple due to the 30-N forces has the magnitude  $M_1 = 30(0.06) = 1.80 \text{ N}\cdot\text{m}$ . The direction of  $\mathbf{M}_1$  is normal to the plane defined by the two forces, and the sense, shown in the figure, is established by the right-hand convention. The couple due to the 25-N forces has the magnitude  $M_2 = 25(0.10) = 2.50 \text{ N}\cdot\text{m}$  with the direction and sense shown in the same figure. The two couple vectors combine to give the components

$$M_y = 1.80 \sin 60^\circ = 1.559 \text{ N}\cdot\text{m}$$

$$M_z = -2.50 + 1.80 \cos 60^\circ = -1.600 \text{ N}\cdot\text{m}$$

1 Thus,  $M = \sqrt{(1.559)^2 + (-1.600)^2} = 2.23 \text{ N}\cdot\text{m}$  Ans.

with  $\theta = \tan^{-1} \frac{1.559}{1.600} = \tan^{-1} 0.974 = 44.3^\circ$  Ans.

The forces  $\mathbf{F}$  and  $-\mathbf{F}$  lie in a plane normal to the couple  $\mathbf{M}$ , and their moment arm as seen from the right-hand figure is 100 mm. Thus, each force has the magnitude

$$[M = Fd] \quad F = \frac{2.23}{0.10} = 22.3 \text{ N} \quad \text{Ans.}$$

and the direction  $\theta = 44.3^\circ$ .

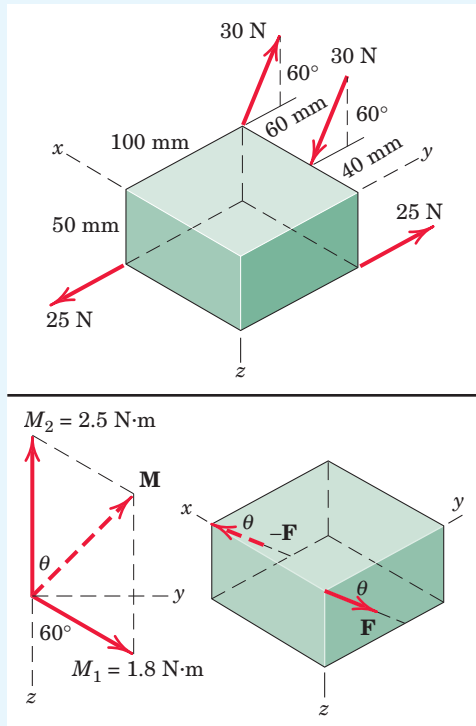

## Helpful Hint

- 1 Bear in mind that the couple vectors are free vectors and therefore have no unique lines of action.

## SAMPLE PROBLEM 2/15

A force of 40 lb is applied at  $A$  to the handle of the control lever which is attached to the fixed shaft  $OB$ . In determining the effect of the force on the shaft at a cross section such as that at  $O$ , we may replace the force by an equivalent force at  $O$  and a couple. Describe this couple as a vector  $\mathbf{M}$ .

**Solution.** The couple may be expressed in vector notation as  $\mathbf{M} = \mathbf{r} \times \mathbf{F}$ , where  $\mathbf{r} = \overrightarrow{OA} = 8\mathbf{j} + 5\mathbf{k}$  in. and  $\mathbf{F} = -40\mathbf{i}$  lb. Thus,

$$\mathbf{M} = (8\mathbf{j} + 5\mathbf{k}) \times (-40\mathbf{i}) = -200\mathbf{j} + 320\mathbf{k} \text{ lb}\cdot\text{in.}$$

Alternatively we see that moving the 40-lb force through a distance  $d = \sqrt{5^2 + 8^2} = 9.43$  in. to a parallel position through  $O$  requires the addition of a couple  $\mathbf{M}$  whose magnitude is

$$M = Fd = 40(9.43) = 377 \text{ lb}\cdot\text{in.} \quad \text{Ans.}$$

The couple vector is perpendicular to the plane in which the force is shifted, and its sense is that of the moment of the given force about  $O$ . The direction of  $\mathbf{M}$  in the  $y$ - $z$  plane is given by

$$\theta = \tan^{-1} \frac{5}{8} = 32.0^\circ \quad \text{Ans.}$$

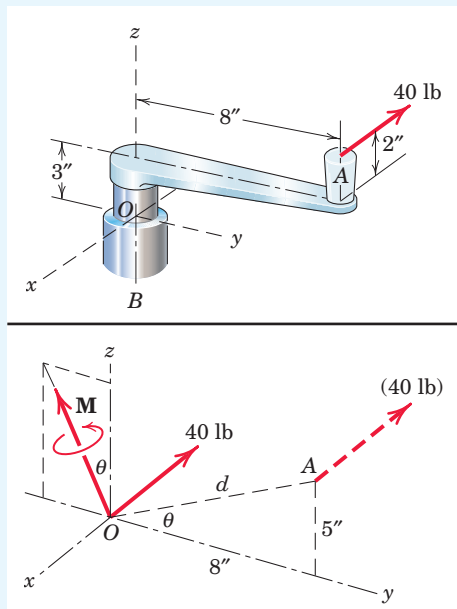

### SAMPLE PROBLEM 2/16

Determine the resultant of the force and couple system which acts on the rectangular solid.

**Solution.** We choose point  $O$  as a convenient reference point for the initial step of reducing the given forces to a force–couple system. The resultant force is

$$\mathbf{1} \quad \mathbf{R} = \Sigma \mathbf{F} = (80 - 80)\mathbf{i} + (100 - 100)\mathbf{j} + (50 - 50)\mathbf{k} = \mathbf{0} \text{ lb}$$

The sum of the moments about  $O$  is

$$\mathbf{2} \quad \mathbf{M}_O = [50(16) - 700]\mathbf{i} + [80(12) - 960]\mathbf{j} + [100(10) - 1000]\mathbf{k} \text{ lb-in.} \\ = 100\mathbf{i} \text{ lb-in.}$$

Hence, the resultant consists of a couple, which of course may be applied at any point on the body or the body extended.

#### Helpful Hints

- 1 Since the force summation is zero, we conclude that the resultant, if it exists, must be a couple.
- 2 The moments associated with the force pairs are easily obtained by using the  $M = Fd$  rule and assigning the unit-vector direction by inspection. In many three-dimensional problems, this may be simpler than the  $\mathbf{M} = \mathbf{r} \times \mathbf{F}$  approach.

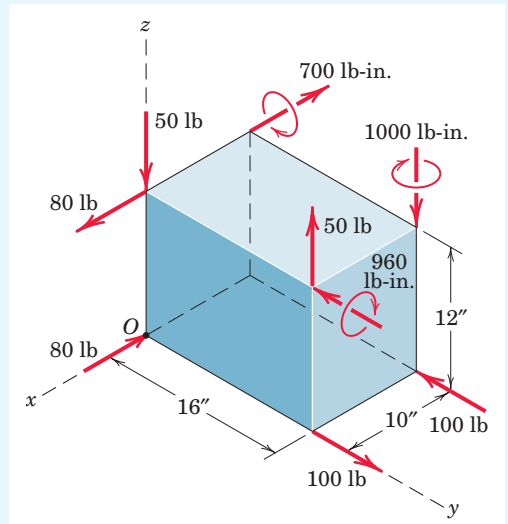

### SAMPLE PROBLEM 2/17

Determine the resultant of the system of parallel forces which act on the plate. Solve with a vector approach.

**Solution.** Transfer of all forces to point  $O$  results in the force–couple system

$$\mathbf{R} = \Sigma \mathbf{F} = (200 + 500 - 300 - 50)\mathbf{j} = 350\mathbf{j} \text{ N} \\ \mathbf{M}_O = [50(0.35) - 300(0.35)]\mathbf{i} + [-50(0.50) - 200(0.50)]\mathbf{k} \\ = -87.5\mathbf{i} - 125\mathbf{k} \text{ N}\cdot\text{m}$$

The placement of  $\mathbf{R}$  so that it alone represents the above force–couple system is determined by the principle of moments in vector form

$$\mathbf{r} \times \mathbf{R} = \mathbf{M}_O \\ (x\mathbf{i} + y\mathbf{j} + z\mathbf{k}) \times 350\mathbf{j} = -87.5\mathbf{i} - 125\mathbf{k} \\ 350x\mathbf{k} - 350z\mathbf{i} = -87.5\mathbf{i} - 125\mathbf{k}$$

From the one vector equation we may obtain the two scalar equations

$$350x = -125 \quad \text{and} \quad -350z = -87.5$$

Hence,  $x = -0.357 \text{ m}$  and  $z = 0.250 \text{ m}$  are the coordinates through which the line of action of  $\mathbf{R}$  must pass. The value of  $y$  may, of course, be any value, as permitted by the principle of transmissibility. Thus, as expected, the variable  $y$  drops out of the above vector analysis.

- 1

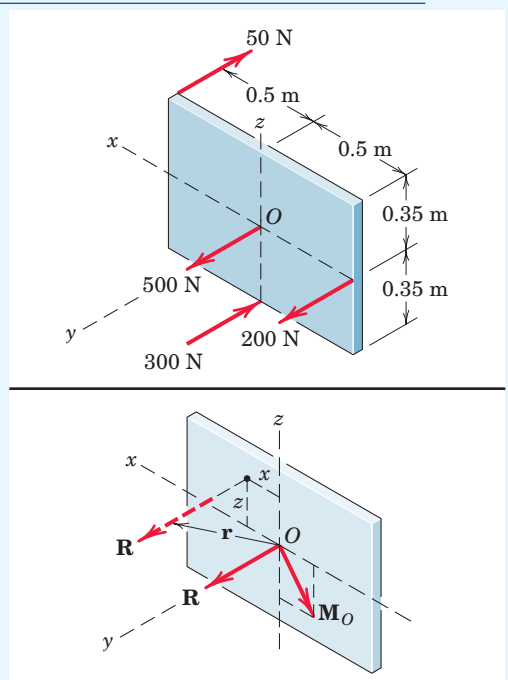

#### Helpful Hint

- 1 You should also carry out a scalar solution to this problem.

## SAMPLE PROBLEM 2/18

Replace the two forces and the negative wrench by a single force  $\mathbf{R}$  applied at  $A$  and the corresponding couple  $\mathbf{M}$ .

**Solution.** The resultant force has the components

$$[R_x = \Sigma F_x] \quad R_x = 500 \sin 40^\circ + 700 \sin 60^\circ = 928 \text{ N}$$

$$[R_y = \Sigma F_y] \quad R_y = 600 + 500 \cos 40^\circ \cos 45^\circ = 871 \text{ N}$$

$$[R_z = \Sigma F_z] \quad R_z = 700 \cos 60^\circ + 500 \cos 40^\circ \sin 45^\circ = 621 \text{ N}$$

Thus, 
$$\mathbf{R} = 928\mathbf{i} + 871\mathbf{j} + 621\mathbf{k} \text{ N}$$

and 
$$R = \sqrt{(928)^2 + (871)^2 + (621)^2} = 1416 \text{ N}$$

The couple to be added as a result of moving the 500-N force is

$$\textcircled{1} [\mathbf{M} = \mathbf{r} \times \mathbf{F}] \quad \mathbf{M}_{500} = (0.08\mathbf{i} + 0.12\mathbf{j} + 0.05\mathbf{k}) \times 500(\mathbf{i} \sin 40^\circ + \mathbf{j} \cos 40^\circ \cos 45^\circ + \mathbf{k} \cos 40^\circ \sin 45^\circ)$$

where  $\mathbf{r}$  is the vector from  $A$  to  $B$ .

The term-by-term, or determinant, expansion gives

$$\mathbf{M}_{500} = 18.95\mathbf{i} - 5.59\mathbf{j} - 16.90\mathbf{k} \text{ N}\cdot\text{m}$$

- $\textcircled{2}$  The moment of the 600-N force about  $A$  is written by inspection of its  $x$ - and  $z$ -components, which gives

$$\begin{aligned} \mathbf{M}_{600} &= (600)(0.060)\mathbf{i} + (600)(0.040)\mathbf{k} \\ &= 36.0\mathbf{i} + 24.0\mathbf{k} \text{ N}\cdot\text{m} \end{aligned}$$

The moment of the 700-N force about  $A$  is easily obtained from the moments of the  $x$ - and  $z$ -components of the force. The result becomes

$$\begin{aligned} \mathbf{M}_{700} &= (700 \cos 60^\circ)(0.030)\mathbf{i} - [(700 \sin 60^\circ)(0.060) \\ &\quad + (700 \cos 60^\circ)(0.100)]\mathbf{j} - (700 \sin 60^\circ)(0.030)\mathbf{k} \\ &= 10.5\mathbf{i} - 71.4\mathbf{j} - 18.19\mathbf{k} \text{ N}\cdot\text{m} \end{aligned}$$

- $\textcircled{3}$  Also, the couple of the given wrench may be written

$$\begin{aligned} \mathbf{M}' &= 25.0(-\mathbf{i} \sin 40^\circ - \mathbf{j} \cos 40^\circ \cos 45^\circ - \mathbf{k} \cos 40^\circ \sin 45^\circ) \\ &= -16.07\mathbf{i} - 13.54\mathbf{j} - 13.54\mathbf{k} \text{ N}\cdot\text{m} \end{aligned}$$

Therefore, the resultant couple on adding together the  $\mathbf{i}$ -,  $\mathbf{j}$ -, and  $\mathbf{k}$ -terms of the four  $\mathbf{M}$ 's is

$$\textcircled{4} \quad \mathbf{M} = 49.4\mathbf{i} - 90.5\mathbf{j} - 24.6\mathbf{k} \text{ N}\cdot\text{m}$$

and 
$$M = \sqrt{(49.4)^2 + (90.5)^2 + (24.6)^2} = 106.0 \text{ N}\cdot\text{m} \quad \text{Ans.}$$

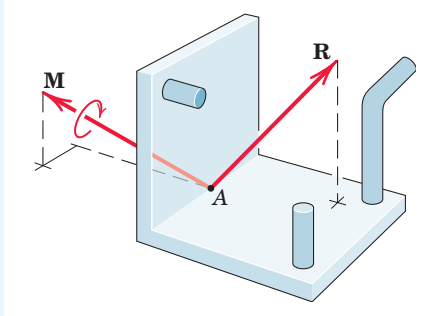
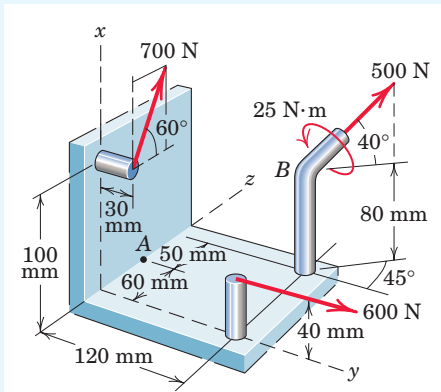

Ans.

## Helpful Hints

- $\textcircled{1}$  *Suggestion:* Check the cross-product results by evaluating the moments about  $A$  of the components of the 500-N force directly from the sketch.
- $\textcircled{2}$  For the 600-N and 700-N forces it is easier to obtain the components of their moments about the coordinate directions through  $A$  by inspection of the figure than it is to set up the cross-product relations.
- $\textcircled{3}$  The 25-N·m couple vector of the wrench points in the direction opposite to that of the 500-N force, and we must resolve it into its  $x$ -,  $y$ -, and  $z$ -components to be added to the other couple-vector components.
- $\textcircled{4}$  Although the resultant couple vector  $\mathbf{M}$  in the sketch of the resultants is shown through  $A$ , we recognize that a couple vector is a free vector and therefore has no specified line of action.

### SAMPLE PROBLEM 2/19

Determine the wrench resultant of the three forces acting on the bracket. Calculate the coordinates of the point  $P$  in the  $x$ - $y$  plane through which the resultant force of the wrench acts. Also find the magnitude of the couple  $\mathbf{M}$  of the wrench.

- 1 Solution.** The direction cosines of the couple  $\mathbf{M}$  of the wrench must be the same as those of the resultant force  $\mathbf{R}$ , assuming that the wrench is positive. The resultant force is

$$\mathbf{R} = 20\mathbf{i} + 40\mathbf{j} + 40\mathbf{k} \quad R = \sqrt{(20)^2 + (40)^2 + (40)^2} = 60 \text{ lb}$$

and its direction cosines are

$$\cos \theta_x = 20/60 = 1/3 \quad \cos \theta_y = 40/60 = 2/3 \quad \cos \theta_z = 40/60 = 2/3$$

The moment of the wrench couple must equal the sum of the moments of the given forces about point  $P$  through which  $\mathbf{R}$  passes. The moments about  $P$  of the three forces are

$$(\mathbf{M})_{R_x} = 20y\mathbf{k} \text{ lb-in.}$$

$$(\mathbf{M})_{R_y} = -40(3)\mathbf{i} - 40x\mathbf{k} \text{ lb-in.}$$

$$(\mathbf{M})_{R_z} = 40(4 - y)\mathbf{i} - 40(5 - x)\mathbf{j} \text{ lb-in.}$$

and the total moment is

$$\mathbf{M} = (40 - 40y)\mathbf{i} + (-200 + 40x)\mathbf{j} + (-40x + 20y)\mathbf{k} \text{ lb-in.}$$

The direction cosines of  $\mathbf{M}$  are

$$\cos \theta_x = (40 - 40y)/M$$

$$\cos \theta_y = (-200 + 40x)/M$$

$$\cos \theta_z = (-40x + 20y)/M$$

where  $M$  is the magnitude of  $\mathbf{M}$ . Equating the direction cosines of  $\mathbf{R}$  and  $\mathbf{M}$  gives

$$40 - 40y = \frac{M}{3}$$

$$-200 + 40x = \frac{2M}{3}$$

$$-40x + 20y = \frac{2M}{3}$$

Solution of the three equations gives

$$M = -120 \text{ lb-in.} \quad x = 3 \text{ in.} \quad y = 2 \text{ in.} \quad \text{Ans.}$$

We see that  $M$  turned out to be negative, which means that the couple vector is pointing in the direction opposite to  $\mathbf{R}$ , which makes the wrench negative.

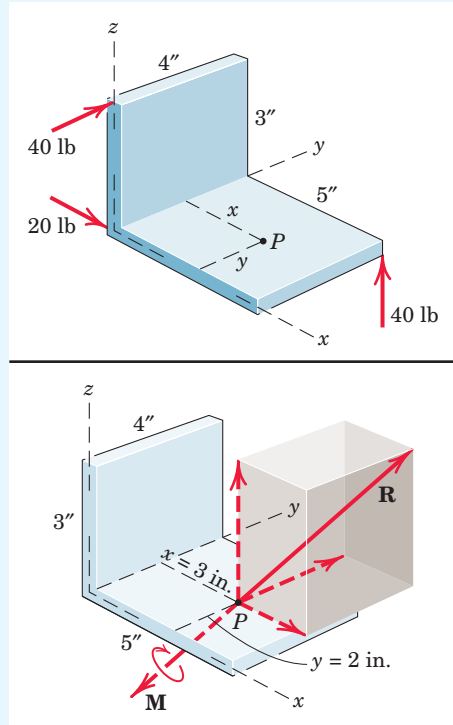

#### Helpful Hint

- 1** We assume initially that the wrench is positive. If  $\mathbf{M}$  turns out to be negative, then the direction of the couple vector is opposite to that of the resultant force.